

ELECTRICAL DATA

TYPICAL HEATER CONNECTIONS

Parallel

Cartridge Heaters are usually wired in a simple parallel connection. Heaters are rated at applied voltage.

Series (single phase)

Cartridge heaters may be wired in series.

1. To reduce wattage in a system, two heaters rated at 240V wired in series will reduce the total wattage to 1/4 of its rated value when 240V is applied. Three similar heaters wired in series will reduce wattage to 1/9 of its rated value.
2. For use at higher voltage—two 120V heaters wired in series for use on 240V, or two 240V heaters wired in series for 480V.

3 Phase Delta

The most commonly used method of making 3 Phase connections. The heaters are arranged in multiples of 3 for a balanced system.

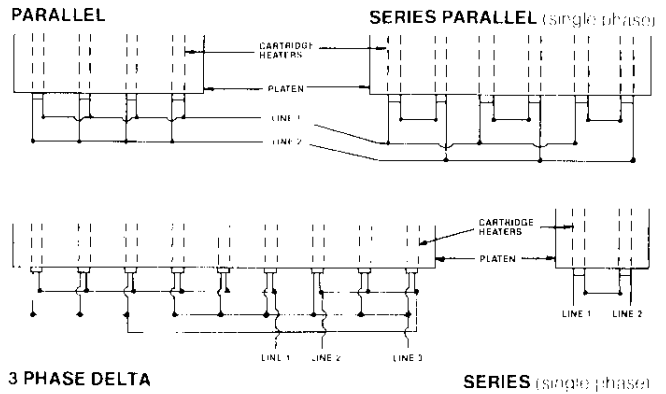

TYPICAL WIRING DIAGRAMS

Single Phase

AC OR DC HTR CIRCUIT

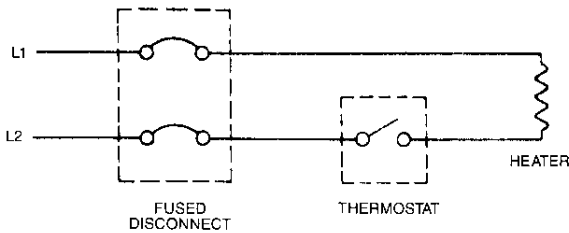

CIRCUIT WITH THERMOSTAT CONNECTED FOR HALF CURRENT LOAD ACROSS EACH CONTACT

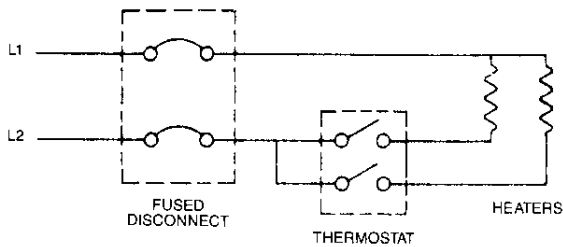

TYPICAL CONNECTIONS WHEN LINE CURRENT EXCEEDS THERMOSTAT RATING

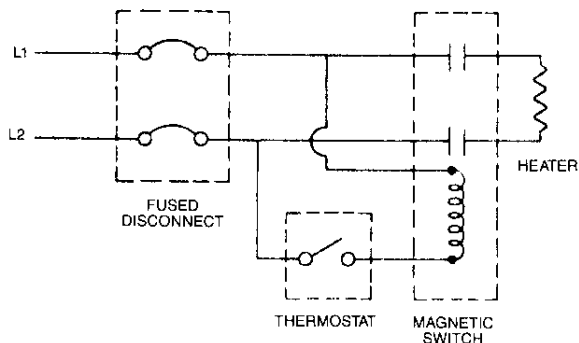

3 Phase

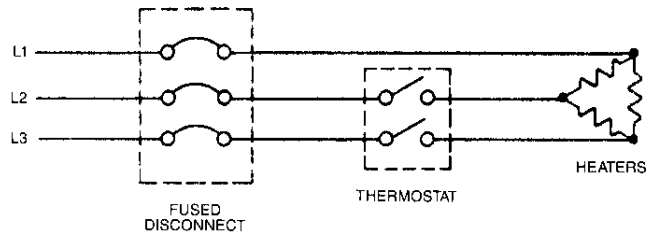

TYPICAL CONNECTION WHEN LINE CURRENT EXCEEDS THERMOSTAT RATING

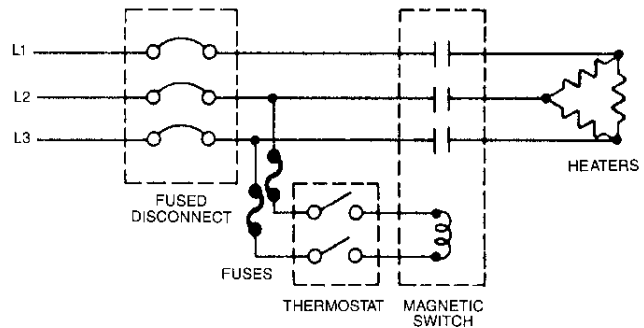

TYPICAL CONNECTION WITH ETR TEMPERATURE CONTROL

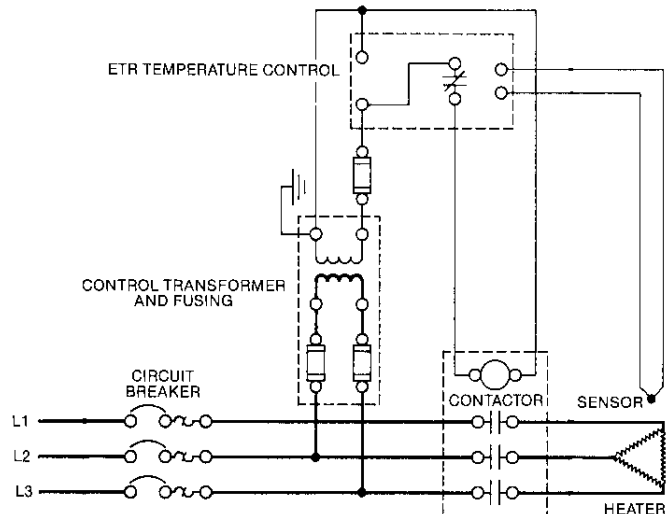

Wattage Change with Voltage Change

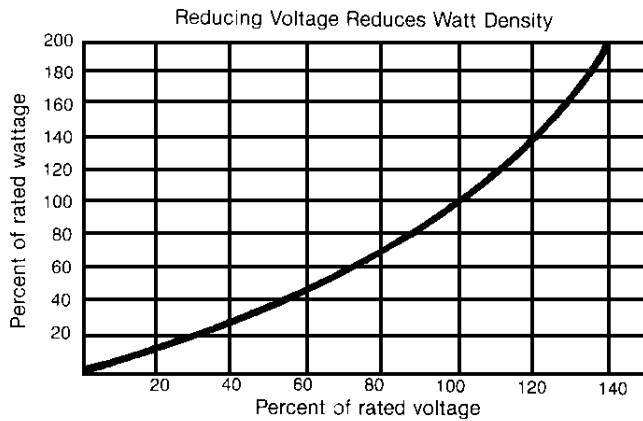

PERCENT RATED WATTS ON REDUCED VOLTAGE	
230-volt heater on 208 volts	—82%
240-volt heater on 208 volts	—75%
480-volt heater on 277 volts	—33%
480-volt heater on 440 volts	—84%
480-volt heater on 318 volts	—44%
550-volt heater on 480 volts	—76%

$$W_2 = W_1 \times \left(\frac{e_2}{e_1}\right)^2$$

Where:

w_2 = New wattage output

w_1 = Rated wattage

e_2 = Applied voltage

e_1 = Rated voltage

Three Phase Circuits

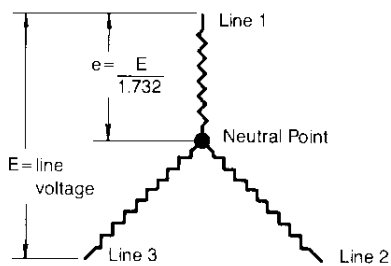

WYE OR STAR

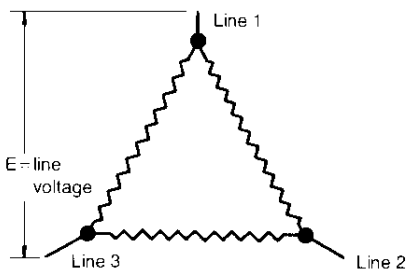

DELTA

If elements are designed for 3-phase Delta connection, wattage output may be reduced to $\frac{1}{3}$ by reconnecting to 3-phase WYE

For current in 3-phase circuits $I = \frac{W}{E \times 1.732}$

For resistance in 3 phase circuit (across any two terminals)

$$R = \frac{E^2}{\frac{1}{2}W}$$

ohms Law

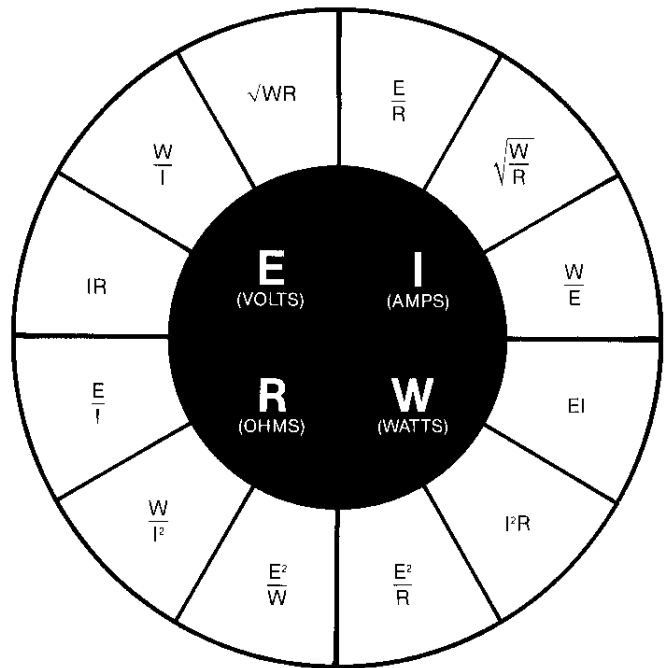

Amperage Conversion Table

Watts	Volts, Single Phase			Volts 3 Phase Balanced Load		Watts
	120	240	480	240	480	
100	.83	.42	.21	.24	.13	100
150	1.25	.63	.31	.36	.18	150
200	1.67	.83	.42	.49	.25	200
250	2.08	1.04	.52	.61	.30	250
300	2.50	1.25	.63	.73	.37	300
350	2.92	1.46	.73	.85	.43	350
400	3.33	1.67	.84	.97	.49	400
450	3.75	1.88	.93	1.10	.55	450
500	4.17	2.08	1.04	1.20	.60	500
600	5.00	2.50	1.25	1.45	.73	600
700	5.83	2.92	1.46	1.70	.85	700
800	6.67	3.33	1.67	1.93	.97	800
900	7.50	3.75	1.87	2.17	1.09	900
1000	8.33	4.17	2.10	2.41	1.21	1000
1100	9.17	4.58	2.30	2.65	1.33	1100
1200	10.0	5.00	2.51	2.90	1.45	1200
1250	10.4	5.21	2.61	3.10	1.55	1250
1300	10.8	5.42	2.71	3.13	1.57	1300
1400	11.7	5.83	2.91	3.38	1.69	1400
1500	12.5	6.25	3.12	3.62	1.82	1500
1600	13.3	6.67	3.34	3.86	1.93	1600
1700	14.2	7.08	3.54	4.10	2.05	1700
1800	15.0	7.50	3.75	4.34	2.17	1800
1900	15.8	7.92	3.96	4.58	2.29	1900
2000	16.7	8.33	4.17	4.82	2.41	2000
2200	18.3	9.17	4.59	5.30	2.65	2200
2500	20.8	10.4	5.21	6.10	3.05	2500
2750	23.0	11.5	5.73	6.63	3.32	2750
3000	25.0	12.5	6.25	7.23	3.62	3000
3500	29.2	14.6	7.30	8.45	4.23	3500
4000	33.3	16.7	8.33	9.64	4.82	4000
4500	37.5	18.8	9.38	10.84	5.42	4500
5000	41.7	20.8	10.42	12.1	6.1	5000
6000	50.0	25.0	12.50	14.50	7.25	6000
7000	58.3	29.2	14.59	16.9	8.5	7000
8000	66.7	33.3	16.67	19.3	9.65	8000
9000	75.0	37.5	18.75	21.7	10.85	9000
10000	83.3	41.7	20.85	24.1	12.1	10000