

STPro™ XB

Portable Infrared Thermometer



Noncontact Temperature Measurement



The STPro Thermometer— The Professional's Rugged Diagnostic Tool.

Maintenance professionals monitor motor malfunctions, research heating and ventilation problems, and monitor electrical motor performance safely and easily with the professional Raytek STPro thermometer. Handheld, and portable, the Raytek STPro infrared thermometer stand up to the day-to-day usage professionals require of their equipment.

The STPro leaps ahead of standard entry level models by providing expanded temperature ranges, higher resolution optics, tighter accuracy and brighter laser sighting. The single dot Extra Bright Laser Point sighting system makes the center point of the measurement area more visible in all conditions, especially outdoors. In less than a second, the large temperature display provides current and MAX surface temperatures.

- 1% accuracy
- Extra Bright Laser Point sighting
- Temperatures up to 535°C/999°F
- MAX temperature display

For equipment maintenance, and heating and ventilation troubleshooting, the professional STPro thermometer makes troubleshooting quick and easy.

 **Raytek®**

Specifications	ST20 XB
Temperature Range	-32°C to 535°C (-25°F to 999°F)
Accuracy (Assumes ambient operating temperature of 23°C [73°F])	-32°C to -26°C (-25°F to -15°F): ±3°C (±5°F) -26°C to -18°C (-15°F to 0°F): ±2.5°C (±4°F) -18°C to 23°C (0°F to 73°F): ±2°C (±3°F) 23°C to 510°C (73°F to 950°F): ±1% of reading or ±1°C (±2°F), whichever is greater Above 510°C (950°F): ±1.5% of reading
Repeatability	±0.5% or ≤ ±1°C (±2°F), whichever is greater
Response Time	≤ 0.5 second (95% of reading)
Spectral Response	8-14µm
Emissivity*	Pre-set at 0.95
Ambient Operating Temp.	0°C to 50°C (32°F to 120°F)
Relative Humidity	10-90%
Storage Temperature	-20°C to 60°C (-13°F to 158°F) without battery
Weight/Dimensions	320g (11oz) 200 x 160 x 55mm (8 x 6 x 2 in)
Power	9V Alkaline or NiCd Battery
Battery Life (Alkaline)	10 hrs w/laser & backlight on 20 hrs w/laser & backlight off
Laser (Class II)	Offset single point Laser Point XB
Typical Distance to Target	Up to 2m (6 ft)
Distance to Spot (D:S)	12:1 at focus point
MAX Temp. Display	✓
Display Hold (7 seconds)	✓
LCD Backlit	✓
Temperature Display	°C or °F selectable
Display Resolution	0.2°C (0.5°F)
Hard Carrying Case	✓
Tripod Mounting	✓
Warranty*	1 year
Additional Options/Accessories	Nylon Holster NIST/DKD Traceable Calibration Certificate (includes 1 year warranty)

* US only. Warranty duration may vary by country.

Raytek Corporation
Worldwide Headquarters
 1201 Shaffer Rd. PO Box 1820
 Santa Cruz, CA 95061-1820 USA
 Tel: 1 800 866 5478
 1 831 458 1110
 Fax: 1 831 425 4561
solutions@raytek.com

To find a Raytek office near you please visit www.raytek.com

Worldwide Service

Raytek offers services including emergency repairs and calibration.
 For more information, contact your local office or e-mail: support@raytek.com



Raytek is an ISO 9001 certified company



Optical Resolution

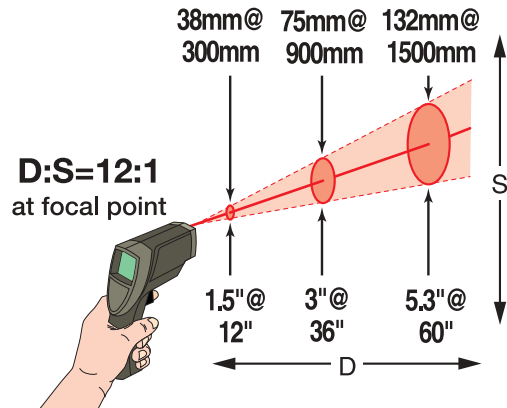

Use the ST20 XB within six feet of the intended target. At greater distances, the measured area will be larger (approximately the distance divided by twelve).

D:S (distance to spot using 90% encircled energy at focal point)

Laser Sighting

The ST20 XB offset single-point Laser Point indicates the approximate center of the measurement area.

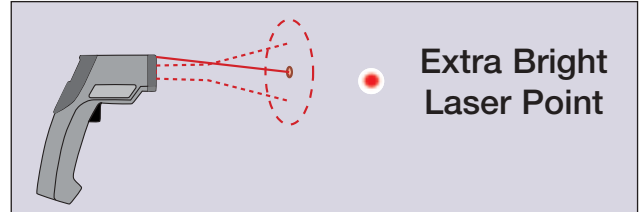

*For more details, visit www.raytek.com/emissivity.htm

www.raytek.com
 for up-to-the-minute features

© 2003 Raytek Corporation (1-1301/ Rev. G) 7/2004
 Raytek and the Raytek logo are registered trademarks,
 and ST and STPro are trademarks of Raytek Corp.
 Specifications subject to change without notice.