

# MI

Datasheet



## Noncontact Temperature Measurement for Industrial Applications



## MI Highlights

- Small sensing head fits where other sensors can't
- Three Ambient operating ranges  
**MID 85°C (185°F) MIC 125°C (257°F) MIH 180°C (356°F)**
- 5-digit backlit LCD user interface
- Adjustable Emissivity, Peak Hold, Valley Hold and Averaging functions
- 1% accuracy from -40°C to 600°C (-40°F to 1112°F)
- 10:1 optics
- Powered by 12-24 VDC at ≤100 mA
- Accessories for cooling and air purging
- Remote electronics box
- RS-232 or optional RS-485 digital communications for remote setup and monitoring

The Raytek MI is a two-piece infrared temperature measurement system with miniature sensing head and separate electronics. The sensor is small enough to be installed just about anywhere, yet it performs as well as much larger systems. The MI electronics include a host of signal processing features which you won't normally find in systems in this price range, including Emissivity, Peak Hold, Valley Hold, and Averaging function, all of which are adjustable on the 5-digit LCD user interface.

Designed for a wide range of applications where the target temperature is in the -40°C to 600°C (-40°F to 1,112°F) range, the sensor is housed in a rugged stainless steel enclosure to ensure long term performance, even in harsh industrial environments with ambient temperatures up to 180°C (356°F) without cooling. Although the MI unit is small in size, it still has the features you need, with 1% accuracy, 10:1 optics and user selectable output signals. And the MI system's response time is as fast or faster than many advanced systems.

Even more features are available with the RS-232 or optional RS-485 communications and the new DataTemp® MultiDrop Software. These features include remote control and monitoring of all sensor variables, a 5V alarm signal triggered by a target temperature or head ambient temperature, an 8-position "recipe" table that can be easily interfaced to an external control system, an external reset signal input for signal processing, and even external inputs for analog emissivity adjustment or reflected energy compensation.

The MI unit's miniature size and low cost make it ideal for installation at multiple points along your process. Accurate. Rugged. Easy to install. Affordable. With the MI, precision infrared temperature measurement is now an economical alternative. Raytek MI – the hottest sensor in the industry.

## Measurement Specifications

Spectral Response	
Model	
LT (Low Temp.)	8 to 14 microns
Optical Resolution:	
LT	10:1
Temperature Range	
Model	
LT	-40°C to 600°C (-40°F to 1112°F); -25°C to 600°C for J-thermocouple output
System Accuracy:	
	±1% of reading or ±1°C, whichever is greater Thermocouple output accuracy ±1% of reading or ±2.5°C, whichever is greater
System Repeatability:	
	±0.5% of reading or ±0.5°C (1°F), whichever is greater
Temperature Coefficient	
MID	0.15K per K or 0.15% per K,
MIC	0.05K per K or 0.05% per K
MIH	0.05K per K or 0.05% per K whichever is greater*
Temperature Resolution:	
LT	0.3°C or 0.5°F
System Response Time: 150ms (95%)	
Emissivity:	
	0.100 to 1.100 digitally adjustable increments of .001
Transmission:	
	0.100 to 1.100 digitally adjustable increments of .001
Signal Processing:	
	Peak hold, valley hold, variable averaging filter, adjustable up to 998 seconds

\* NIST/DKD certified models available with 0.05K per K

## Nominal Optical Specifications

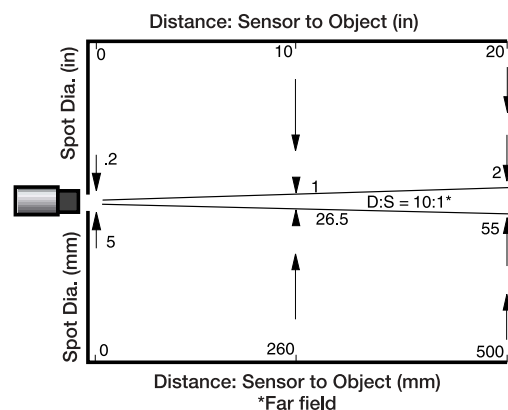

D:S is the optical resolution expressed as a ratio of the distance to the measurement spot divided by the diameter of the spot.

Optical resolution for the MI is 10:1.

Nominal spot size based on 90% energy.

## Electrical Specifications

Outputs:	Scalable 4-20mA, 0-20mA, 0-5V, J or K thermocouple
Alarm Relay	10mV/°C Head Ambient signal
Cable Length:	1 m (3.2 ft) standard
Output Impedance (T/C output):	20 ohms
Minimum Load Impedance (mV output):	100K ohms
Maximum Loop Impedance (mA output):	500 ohms with 24 VDC power supply
Current Draw:	100 mA
Power Supply:	12-24 VDC

## Sensor Specifications

Environmental Rating:	NEMA-4 (IP 65)
Ambient Temperature Range:	
MID	0°C to 85°C (32°F to 185°F)
MIC	0°C to 125°C (32°F to 257°F)
MIH	0°C to 180°C (32°F to 356°F)
Electronics housing	0°C to 65°C (32°F to 150°F)
Storage Temperature:	-18°C to 85°C (0 to 185°F)
Relative Humidity:	10 to 95%, non-condensing
Construction:	
Sensing head	Stainless steel
Electronics housing	Zinc, die-cast

### Weight:

Sensing head (w/1 m cable)	50 g (1.75 oz)
Electronics housing	270 g (9.5 oz)

Shock IEC 68-2-27 (MIC ST 810D)-50g's, 11 ms on any axis  
 Vibration 68-2-27 (MIC ST 810D)-3g's, 11-200 Hz on any axis

## Sensor Dimensions

### Sensing Head

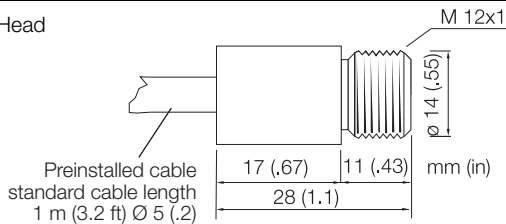

### Electronics Housing

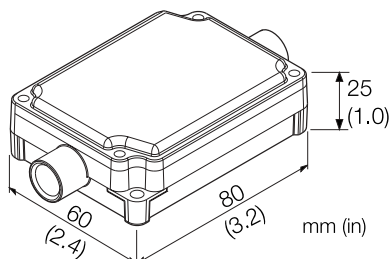

## Accessories / Options

Each standard MI package includes a sensing head, one mounting nut, 1 m (3.2 ft) of cable, die-cast housing with premounted electronics, and an operator's manual. Longer cables up to 15m (50 ft) maximum are available and must be specified at time of order.

Adjustable or fixed mounting bracket for sensing head (XXXMIACAB or XXXMIACFB)

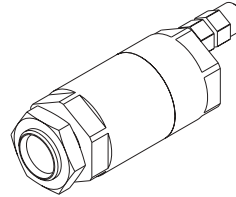
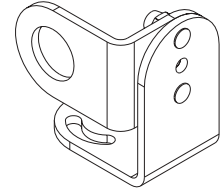

Air purge jacket to keep lens or right angle mirror clean (XXXMIACAJ)

Viewport accessory for MI electronics (XXXMIACV)



## DataTemp® Multidrop software puts you in control.

## Multidrop Network Installation

RS-485 sensors can be configured in a multidrop network or point-to-point installation. In multidrop networks, a dedicated PC with DataTemp Multidrop software supports online system monitoring and configuration.

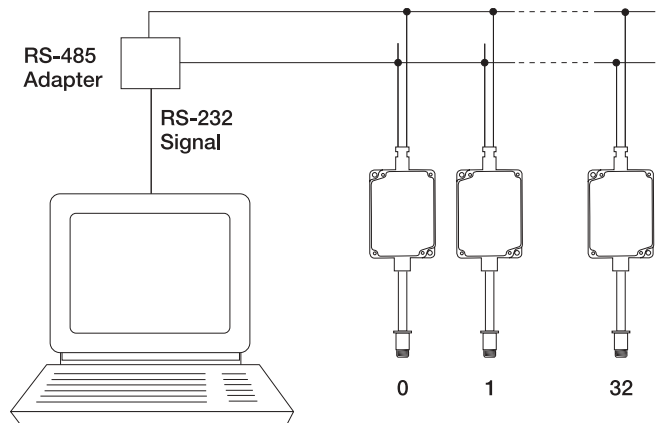

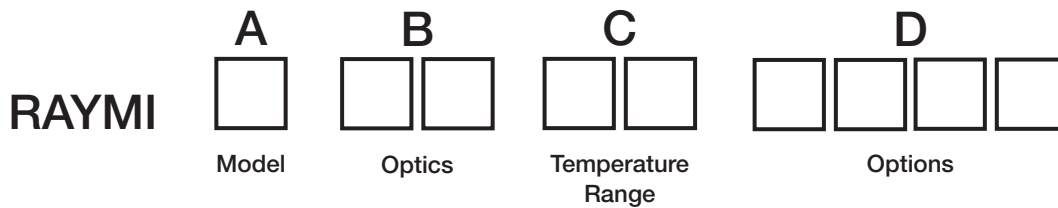

Model	Description
RAYMI	Modular Infrared Thermometer
Code A	Model
D	Standard model includes selectable 4-20mA/0-20mA, 0-5 V, or J/K thermocouple output and head temperature output 85°C (185°F) ambient operating range .05k/k temperature coefficient
C	MID with DKD/NIST calibration certificate and optimized performance 125°C (257°F) ambient operating range .05k/k temperature coefficient
H	MID with DKD/NIST calibration certificate and optimized performance 180°C(356°F) ambient operating range .05k/k temperature coefficient
Code B	Optics
10	10:1 D:S sensor with 1m wiring cable
Code C	Temperature Range
LT	-40°C to 600°C (-40°F to 1112°F); 8 – 14 microns
Code D	Options
4	RS485 communication for multidrop networks
CB3	3m (9.8') cable
CB8	8m (26') cable
CB15	15m (49') cable
V	Display window for electronics housing
Typical Model Number	<b>RAYMIH10LTCB3</b>

**Raytek Automation Products: Noncontact Temperature Measurement for Industrial Applications**

**Raytek Corporation**  
**Worldwide Headquarters**  
 1201 Shaffer Rd. PO Box 1820  
 Santa Cruz, CA 95061-1820 USA  
 Tel: 1 800 866 5478  
 1 831 458 1110  
 Fax: 1 831 425 4561  
 solutions@raytek.com

**www.raytek.com**  
*for up-to-the-minute features*

To find a Raytek office near you please visit [www.raytek.com](http://www.raytek.com)

**Worldwide Service**  
 Raytek offers services including emergency repairs and calibration.  
 For more information, contact your local office or e-mail: [support@raytek.com](mailto:support@raytek.com)



Raytek is an ISO 9001 certified company

© 2004 Raytek Corporation (2-1702 Rev. F) 10/2004  
 Raytek, the Raytek logo and DataTemp are registered trademarks  
 Compact Series and MID are trademarks of Raytek Corporation.  
 Specifications subject to change without notice.