

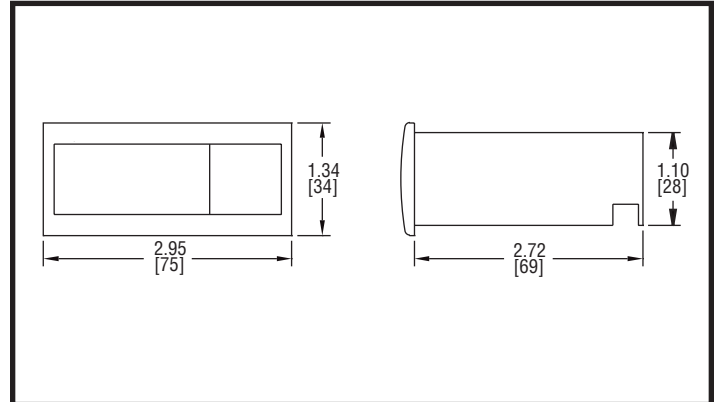

## Series TS Digital Temperature Switch



## Specifications - Installation and Operating Instructions

**DESCRIPTION**

The TS Digital Temperature Switch is designed for many heating and cooling applications. The probe temperature is displayed on the bright 3-digit, red LED. The user is able to program 12 different parameters including set point, hysteresis, cycle time, and ambient probe adjustment using the tactile front keypad. The unit features error or alarm messaging and password protection. Select between 8 amp SPDT or 16 amp SPST relays, temperature display in °F or °C, and 110 VAC, 230 VAC, or 12 VDC power supplies. The TS includes a thermistor with 5 ft (1.5 m) cable, fitting clips for panel mounting, and instruction manual.

**INSTALLATION**

**NOTE:** Unit must be mounted away from vibration, impacts, water and corrosive gases.

- Cut hole in panel 2.80 x 1.14 inches (71 x 29mm).
- Apply silicone (or rubber gasket) around the perimeter of the hole to prevent leakage.
- Insert unit into hole in the panel.
- Slide removable fitting clips onto unit from the back until secure to panel.
- Remove back cover to wire unit.
- Wiring diagram is displayed on the top of the unit.
- (Note: PROBE CABLE LENGTH MUST NOT EXCEED 328 ft (100 m). DO NOT INSTALL PROBE CABLE NEAR POWER CABLES)
- Replace cover once wiring is completed.

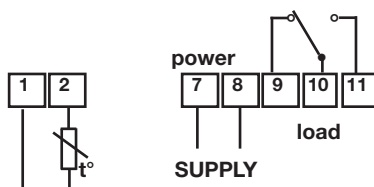
**WIRING DIAGRAM****PHYSICAL DATA**

**Probe range:** -58 to 302°F (-50 to 150°C)

**Input:** 1.5-inch (4 cm) thermistor (1000Ω @ 25°C) with 5-foot (1.5 m) cable

**Accuracy:** ±1°

**Resolution:** ±1 digit

**Output:** 8 amp SPDT or 16 amp SPST relay; @ 250 VAC, (Depending on model)

**Horsepower Rating (HP):** 1/3 HP for 8 amp and 3/4 HP for 16 amp

**Supply Voltage:** 110 VAC, 230 VAC or 12 VDC (Depending on model)

**Supply Power:** 4 VA (230 V)

**Ambient Temp:** 14 to 158°F (-10 to 70°C)

**Storage Temperature:** -4 to 176°F (-20 to 80°C)

**Front Panel Protection:** NEMA 4 (IP65)

**Display:** 3-Digit, Red or Green (Depending on model)

**PARAMETERS**

	Description	Units	Range
SP	Set point	Degrees	r1 to r2
r0	Differential or hysteresis	Degrees	1 to 20
r1	Lower Value Set Point	Degrees	-50 to 150°
r2	Higher Value Set Point	Degrees	-50 to 302°F (-50 to 150°C)
d0	Heating or Cooling Control	Option	Ht/Co
d2	Time for Defrosting	Minutes	0 to 59 min.
d8	Interval Time between Defrosting	Hours	1 to 24 hr.
c0	Min. stop time for Load	Minutes	0 to 59 min.
c1	Continuous Cycle Time	Hours	0 to 24 hr.
P1	Ambient Probe Adjustment	Degrees	-10 to 10
H5	Parameter Access code	Numeric	0 to 99 (SET AT 00 FROM FACTORY)
t0	Max. Temp. on Display	Degrees	-50 to 302°F (-50 to 150°C)

## PARAMETER DESCRIPTIONS

**SP**= Set Point- Desired Regulation Temperature

**r0**= Differential or Hysteresis

**r1**= Lower Set point Limit

**r2**= Higher Set Point Limit

**d0**= Heating or Cooling Control-This control only does regulation cycles. Neither defrosting nor continuous cycles exist.

*Heating: To choose Heating Control- Set  $d0=Ht$  (The output is activated when  $TS1$  (temperature of ambient probe) is less than or equal to Set Point.)*

*$TS1 \leq SP$ . It then disconnects when  $TS1 \geq SP-r0$ .*

*Cooling: To choose Cooling Control - Set  $d0=Co$  (The output is activated when  $TS1 \geq SP+r0$ . The display will switch off when  $TS1 \leq Set$ .*

**d2**= Duration of Defrosting Time (The value programmed from the factory is  $d2=15$  minutes. [*Ht- defrosting will never start, if  $Co=0$ , defrosting will never start.*])

**d8**= Interval time between defrosting.

**c0**= Minimum time between start and stop.

**c1**= Continuous cycle time.

**P1**= Ambient Probe Calibration. (Offset degrees to adjust ambient probe. If the probe is not placed in the exact point that is to be measured, use a standard thermometer and adjust the difference in this parameter.)

**H5**= Access to probe parameters. (This code is set to 00 from the factory.)

**t0**= Maximum temperature on display. (Temperature limit for defrosting).

## PARAMETER PROGRAMMING

*Access set point (SP) without code protection.*

- Press SET. SP text will appear on the display.
- Press SET again. The real value is shown on the display.
- The value can be modified with the UP and DOWN arrows.
- Press SET to enter any new values.
- Press SET and DOWN at the same time to quit programming or wait one minute and the display will automatically exit programming mode.

*\*The keyboard code can be reset to ZERO by turning off the controller and turning it on again while keeping the SET key depressed*

### *Access to all code protected parameters.*

- Press SET for 8 seconds. The access code value 00 is shown on the display. (Unit comes with code set at 00 from factory).
- With the UP and DOWN arrows, code can be set to user needs.
- Press SET to enter the code. If it is correct, the first parameter label is shown on the display (SP).
- Move to the desired parameter with the UP and DOWN keys.
- Press SET to view the value on the display.
  
- The value can be modified with the UP and DOWN arrows.
- Press SET to enter the value and exit to text parameter.
- Press SET and DOWN at the same time to quit programming or wait one minute and the display will automatically exit programming mode.

## LED INDICATIONS

**OUT** This indicates the load is connected. The system waits for the programmed minimum stop time of the load.

**Def** This indicates defrosting is activated.

## DISPLAY MESSAGES

In normal operation, the probe temperature will be shown on the display. In case of alarm or error, the following messages will be shown:

- **Er** = Memory Error
- **--** = Short-Circuit Probe Error
- **oo** = Open Probe Error

## MAINTENANCE/REPAIR

After final installation of the TS Series Digital Temperature Switch, no routine maintenance is required. A periodic check of system calibration is recommended. These devices are not field repairable and should be returned to the factory if recalibration or other service is required. After first obtaining a Returned Goods Authorization (RGA) number, send the material, freight prepaid, to the following address. Please include a clear description of the problem plus any application information available.

Dwyer Instruments  
Attn: Repair Department  
102 Highway 212  
Michigan City, IN 46360