

INSTRUCTIONS FOR THE Panel Pro™ 45, 4³/₄ DIGIT MICROPROCESSOR BASED TEMPERATURE / PROCESS INDICATOR



LOVE CONTROLS

a Division of Dwyer Instruments, Incorporated
PO Box 338 ○ Michigan City, IN 46361-0338
(800) 828-4588 ○ (219) 879-8000 ○ FAX (219) 872-9057
www.love-controls.com

December, 2000

949-1293





CONTENTS



INSTALLATION	4
WIRING	5
Wiring for Transmitter inputs	6
Wiring for Optional Inputs and Outputs	7
FRONT PANEL KEY FUNCTIONS	8
NOTATION CONVENTIONS FOR THE MENUS	10
THE HOME DISPLAY	10
OPERATION AND PROGRAMMING OF OPTIONS	10
MENU SELECTIONS	11
PRIMARY MENU	11
SECONDARY MENU	12
SECURE MENU	13
ALARM TYPE AND ACTION (if present)	15
SPECIFICATIONS	17
DIAGNOSTIC ERROR MESSAGES	19
DIAGNOSTIC ERROR MESSAGES	20
DIMENSIONS	20





GETTING STARTED

1. Install the indicator as described on page 4.
2. Wire your indicator following the instructions on page 5. If you are using a two-wire transmitter as an input, see the drawing and instructions on page 6. Option wiring instructions are on Page 7. Option descriptions and specific instructions start on page 10.
3. Most indicators do not need many (if any) program changes to work on your process. For best results when programming changes are necessary, make all the necessary changes in the Secure Menu (page 13) before making changes to the Secondary Menu (page 12). If error messages occur, check the Diagnostic Error Messages on page 19 for help.

Take the example of a PP45 that comes from the factory programmed for type J thermocouples. Suppose for this example you wish to change the input to type K and ° C.

First, enter the Secure menu by pressing and holding the  UP ARROW and  ENTER keys for at least 5 seconds. Press the  INDEX key until the display shows *InP* and press the  DOWN ARROW until the display shows *CR*. Don't forget to press the  ENTER key to retain your setting.

Next, press the  INDEX key to display *Un t*. Press the  DOWN ARROW until the display shows *t*. Press  ENTER.

The necessary program changes are now complete. After 60 seconds the display will switch back to the temperature reading. If you want to return faster, press the  UP ARROW and  ENTER keys (at the same time) and then press the  DOWN ARROW and  INDEX keys (again at the same time). This will 'back out' of the menu and immediately display the temperature reading.

MODEL IDENTIFICATION

P P 4 5 —

Alarms

0 = None

1 = Yes

OPTION -

Blank or one of the options listed below

Options:

932 Analog Retransmission of Process Variable, 4 to 20 mAdc.

933 Analog Retransmission of Process Variable, 0 to 10 Vdc.

995 RS-232 Serial Communications, Modbus Protocol.

996 RS-485 Serial Communications, Modbus Protocol.

INSTALLATION

Mount the instrument in a location that will not be subject to excessive temperature, shock, or vibration. All models are designed for mounting in an enclosed panel.

Select the position desired for the instrument on the panel.

Prepare the panel by cutting and deburring the required opening using the dimensions shown in Figure 1.

From the front of the panel, slide the instrument through the cut out. The housing gasket should be against the housing flange before installing.

From the rear of the panel slide the mounting collar

over the housing. Hold the housing with one hand and using the other hand, push the collar evenly against the panel until the springs are compressed. The ratchets will hold the mounting collar and housing in place.

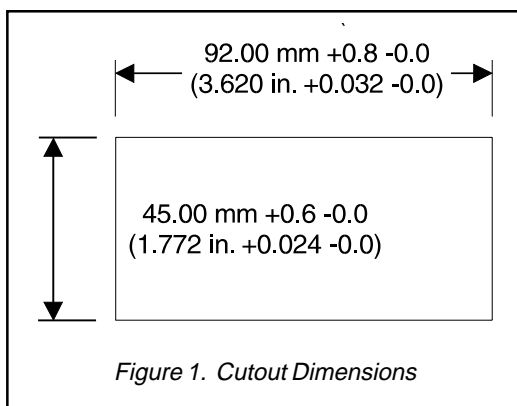

WIRING



Caution: Do not run thermocouple or other class 2 wiring in the same conduit as power leads. Use only the type of input (thermocouple, RTD probe, etc.) for which the indicator has been programmed. Maintain separation between wiring of sensor, auxiliary in or out, and other wiring.

For thermocouple input always use extension leads of the same type designated for your thermocouple.

For supply connections use No. 16 AWG or larger wires rated for at least 75°C. Use copper conductors only. All line voltage output circuits must have a common disconnect and be connected to the same pole of the disconnect.

Indicator wiring is as shown in Figure 2.

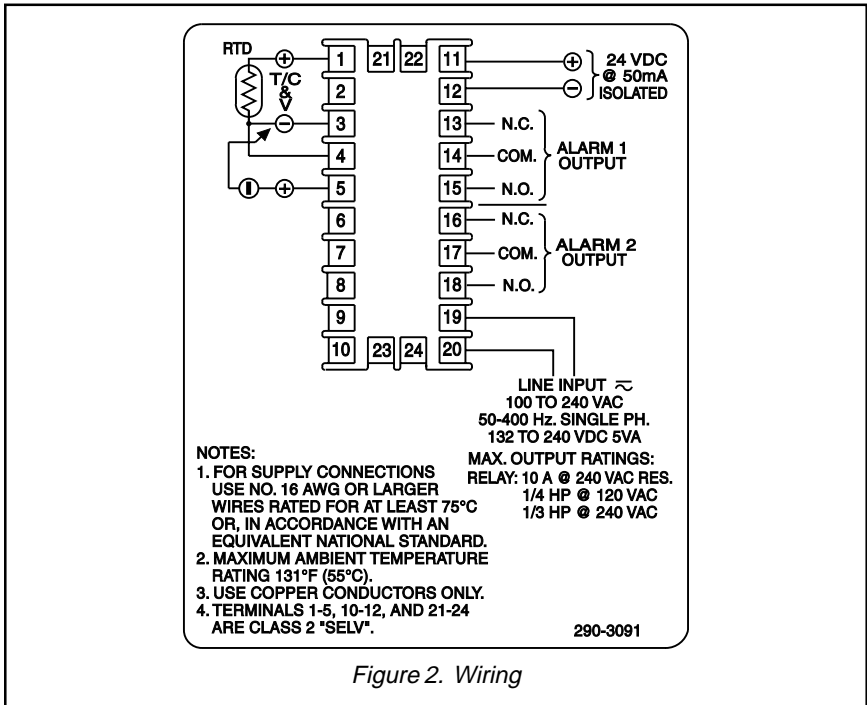

Figure 2. Wiring



DANGER: Unused terminals can not be used as tie points for other circuits. Do not make connections to the instrument other than those shown. Use of terminals for purposes not shown may cause damage to the instrument, other devices, and may result in personal injury or death.

Wiring for Transmitter inputs

Wire power and outputs as shown on previous page. Two-wire transmitters wire as shown below.

For three or four wire transmitters follow the wiring instructions provided with your transmitter.



DO NOT WIRE THE 24 VOLT POWER SUPPLY ACROSS THE INPUT OF THE INDICATOR. DAMAGE TO THE INDICATOR INPUT CIRCUITRY WILL RESULT.

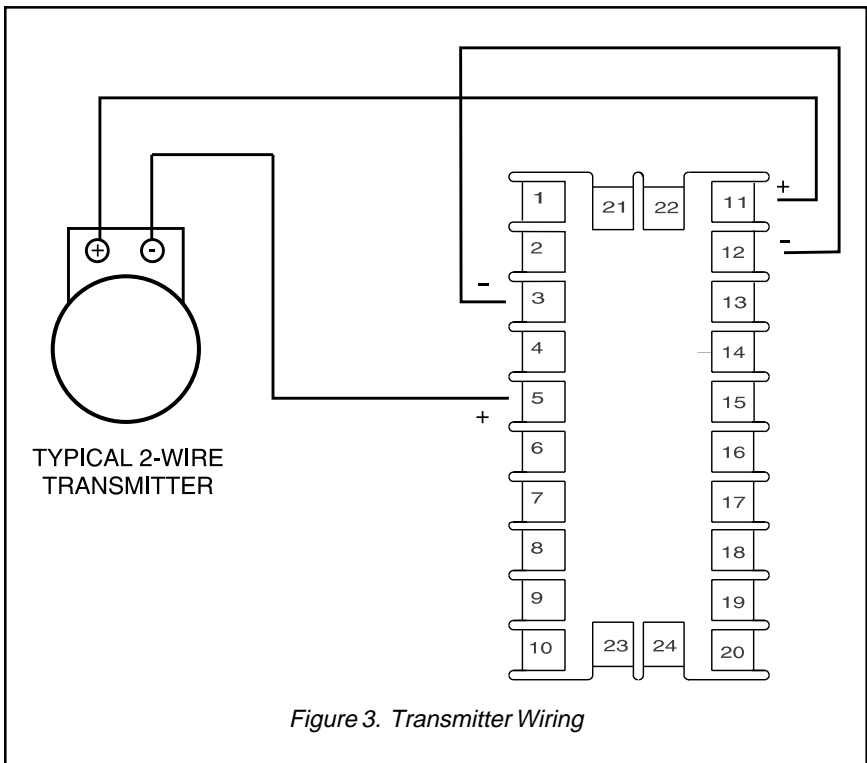

Wiring for Optional Inputs and Outputs

Wire indicator as shown on page 5. Wiring for options is shown opposite. All wiring shown below is Class 2. Shielded twisted pair is recommended for Options 995 and 996.



DO NOT RUN SIGNAL WIRING IN THE SAME CONDUIT OR CHASE AS THE POWER WIRING. ERRATIC OPERATION OR DAMAGE TO THE INDICATOR CIRCUITRY WILL RESULT.

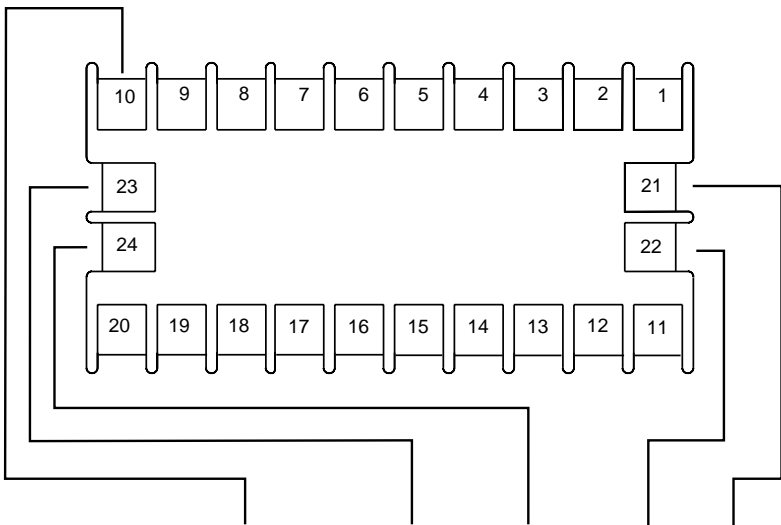

OPTION	10	23	24	22	21
932	None	None	None	-	+
933	None	None	None	-	+
995	Signal Ground	Data In	Data Out	None	None
996	None	B	A	None	None

Figure 4. Option Wiring

Note: The RS-485 standard uses the conductor designations 'A' and 'B'. Non-standard devices may use '+' and '-' (plus and minus). Generally, the '+' will correspond to the 'B' conductor and the '-' to the 'A' conductor. Check the documentation with the RS-485 device you are using for further information. Reversal of the 'A' and 'B' conductors will not damage the instrument.

FRONT PANEL KEY FUNCTIONS



Key functions are as follows:

INDEX: Pressing the INDEX key advances the display to the next menu item. May also be used in conjunction with other keys as noted below.

UP ARROW: Increments (raises) a value, changes a menu item, or selects the item to ON. The maximum value obtainable is 32750 regardless of decimal point placement.

DOWN ARROW: Decrements (lowers) a value, changes a menu item, or selects the item to OFF. The minimum value obtainable is -32750 regardless of decimal point placement.

ENTER: Pressing ENTER stores the value or the item changed. If not pressed, the previously stored value or item will be retained. The display will flash once when ENTER is pressed.

TARE: Press the TARE key to zero the display to the level of input at the time the key is pressed. The display will indicate InPC (see Input Correct in Secondary Menu on page 12) and the amount of offset from zero for that reading. You may change this value by using the **UP ARROW** or **DOWN ARROW** keys. Press **ENTER** to retain. Press the **TARE** key to exit without changing. The indicator over the key will light when the Tare function is in operation.

RST RESET: Resets alarm(s) when pressed (if alarm conditions have been corrected).

UP ARROW & ENTER: Pressing these keys simultaneously brings up the **secondary menu** starting at the alarm, tune, or cycle item (depending on programming). Pressing these keys for 5 seconds will bring up the **secure menu**.

INDEX & DOWN ARROW: Pressing these keys simultaneously will allow backing up one menu item, or if at the first menu item they will cause the display to return to the **primary menu**. If an alarm condition has occurred, these keys may be used to reset the alarm.

INDEX & ENTER: Pressing these keys simultaneously and holding them for 5 seconds allows recovery from the various error messages. The following menu items will be reset:





AL #H: Alarm inhibit

OPEN INP: Input error message



bad INP: Input error message **CHEC CAL:** Check calibration error



Correct the problems associated with the above conditions before using these reset keys. More than one error could be present. Caution is advised since several items are reset at one time.

While in the **Primary or Secondary Menu**, if no key is pressed for a period of 30 seconds, the display will return to the HOME position displaying the temperature value. While in the **Secure Menu**, if no key is pressed for a period of 60 seconds, the display will return to the HOME position displaying the temperature value. Outputs are disabled (turned off) when the **Secure Menu** is active.

NOTE: To move to the **Home** position quickly from any other menu, press the   **UP ARROW & ENTER** keys followed by pressing the   **INDEX & DOWN ARROW** keys.

SECURITY LEVEL SELECTION

Four levels of security are provided. The display shows the current security level. To change security levels change the password value using the  **UP ARROW** or  **DOWN ARROW** keys and pressing the  **ENTER** key. Refer to the password table (following) for the correct value to enter for the security level desired. The **SECr** menu item security level may be viewed or changed at any time regardless of the present security level.

To set the access level to, for example, **2**, at the **SECr** menu item press the  **UP ARROW** key until the upper display show the password, **101**. Press the  **ENTER** key. The display will blink, and return with the level value, **2**, in the upper display.

The password values shown in the table cannot be altered, so retain a copy of these pages for future reference. This is the only reference made to password values in this instruction book.

PASSWORD TABLE



Security Menu	Level Status	Displayed Value When Viewed	Password Value To Enter
Primary Secondary Secure	Locked Locked Locked	1	110
Primary Secondary Secure	Unlocked Locked Locked	2	101
Primary Secondary Secure	Unlocked Unlocked Locked	3	011
Primary Secondary Secure	Unlocked Unlocked Unlocked	4	111

NOTATION CONVENTIONS FOR THE MENU

Because of the number of features available in this indicator, information is included that may not apply to your specific indicator. All usable features are included in this book, but may not be used in your process.

THE HOME DISPLAY

The home display is the normal display while the indicator is operating. If no errors or functions are active, the HOME display will indicate the Process Variable (the temperature, pressure, flow, RH, etc., that is being measured).

When menu items are displayed, the display alternates showing the menu item selected and the value for that menu item. Pressing the  UP ARROW or  DOWN ARROW keys cause the display to show the value.

Items that can change the HOME display are error messages. Description of error messages start on Page 19.

OPERATION AND PROGRAMMING OF OPTIONS

Option 932, 933, Analog Retransmission.

The analog retransmission option allows the Process Variable to be sent as an analog signal to an external device. The signal may be either 0 to 10 VDC (Option 933) or 0 (or 4) to 20 mADC (Option 932). The output may be changed in the field from one to the other by the toggle switch located on the top printed circuit board. Wire the output as shown on page 7.

To set up the analog retransmission, first determine the scale range that the analog signal will represent. The selected scale must be between -32500 and +32500 degrees or counts. In the Secondary Menu set **POL** for the scale value that will be represented by the low end of the analog signal (0 Volts or 0 mA). Set **POH** for the scale value that will be represented by the high end of the analog signal (10 Volts or 20 mA).

If you require a suppressed scale or output, you may use the following equations to determine the proper settings for **POL** and **POH**.

$K = \frac{\text{(Highest desired scale reading - Lowest desired scale reading)}}{\text{(Maximum desired analog signal - Minimum desired analog signal)}}$

$POH = \text{(Maximum possible analog output - Maximum desired analog signal)} * K + \text{Highest desired analog reading.}$

$POL = \text{Lowest desired scale reading} - \text{(Minimum desired analog output)} * K.$

Note: The output of the analog retransmission is calculated based on the number of counts of the output span overlaid on the number of counts programmed for the input span. The minimum resolution of the output will be one step for each count of the display (degree, tenth of a degree, or count). The minimum value for a step is 156µV (Option 933) or 0.313µA (Option 932). Steps may be of greater value depending on the scaling of the input and the **POL** and **POH**.

Options 995 (RS-232 MOD-BUS RTU Serial Communication), and 996 (RS-485 MOD-BUS RTU Serial Communication).

The serial communications options allow the indicator to be written to and read from a remote computer or other similar digital device. Communication is allowed either through a RS-232 (Option 995) port, or a RS-485 (Option 996) port.

Wire the communication lines as shown on Page 7. Wiring for the RS-485 is run from indicator to indicator in a daisy chain fashion with a termination resistor (120 ohms) across the transmit and receive terminals of the last indicator in the chain.

Select the indicator address and communication baud rate with the **Addr** and **bAUD** menu items in the Secure Menu.



THE BAUD RATE AND ADDRESS MENU ITEMS WILL TAKE EFFECT ON THE NEXT POWER UP OF THE INDICATOR. BE SURE TO POWER CYCLE THE INDICATOR BEFORE USING THE NEW BAUD RATE AND ADDRESS.

In operation, you have the option of preventing a write command from the host computer. To prevent the host from writing to the indicator change the **LOrE** menu item in the Secondary Menu to **LOC**. To allow the host to write commands to the indicator set **LOrE** to **rE**. (The host does have the ability to change the **LOrE** state, but it is not automatic.)

If your system depends on constant reading or writing to and from the host, you may wish to set the No Activity Timer (**nAt**) to monitor the addressing of the indicator. When the **LOrE** is set to **rE** and the **nAt** is set to any value other than Off, the indicator will expect to be addressed on a regular basis. If the indicator is not addressed in the time set by the value of **nAt**, then the indicator will display the error message **CHCC LOrE**. To clear the message set **LOrE** to **LOC**.

MENU SELECTIONS

PRIMARY MENU

Press **INDEX** to advance to the next menu item. The display will alternate between the menu item and the programmed value. Press **UP ARROW** or **DOWN ARROW** keys to change the programmed value in the display. Press **ENTER** to retain the value.

Alarms are optional. If alarms are not present, the Primary Menu will not exist.

ALo Alarm 1 Low Set Value: May not appear depending on **AL !** setting in **Secure Menu**.

AH! Alarm High Set Value: May not appear depending on **AL !** setting in **Secure Menu**.

- AL2L** Alarm 2 Low Set Value: May not appear depending on **AL2** setting in **Secure Menu**.
- AL2H** Alarm 2 High Set Value: May not appear depending on **AL2** setting in **Secure Menu**.

SECONDARY MENU

Press **▲** **↩** **UP ARROW & ENTER**. Press **↻** **INDEX** to advance to the next menu item. The display will alternate between the menu item and the programmed value. Press **▲** **UP ARROW** or **▼** **DOWN ARROW** to change the programmed value in the display. Press **↩** **ENTER** to retain the value.

PEA The Peak feature stores the highest input the instrument has measured since the last reset or Power On. At Power On PEA is reset to the present input. To manually reset the value **PEA** must be displayed. Press the **↩** **ENTER** key to reset. **PEA** will be reset and display the present input value.

VAL The Valley feature stores the lowest input the instrument has measured since the last reset or Power On. At Power On **VAL** is reset to the present input. To manually reset the value **VAL** must be displayed. Press the **↩** **ENTER** key. **VAL** will be reset and display the present input value.

INPC Input Correction: Select **±500** °F, °C, or **±32750** counts. This feature allows the input value to be changed to agree with an external reference or to compensate for sensor error. **Note:** **INPC** is reset to zero when the input type or the decimal position is changed.

FILT Digital Filter: Select **OFF**, **1** to **31**. In some cases the time constant of the sensor, or noise could cause the display to jump enough to be unreadable. A setting of 5 is usually sufficient to provide enough filtering for most cases, (5 represents approximately a 1 second time constant).

POL (Option 932, 933, Analog Retransmission Output) Process Output Low: Select from **-32750** counts up to to any value at least 100 units less than **POH**. (minimum span 100 units, to a maximum span of 65500 counts).

POH (Option 932, 933, Analog Retransmission Output) Process Output High: Select to any value at least 100 units greater than **POL** to a maximum span of 65500 counts.

LORE (Option 995, 996, Serial Communications) Local / Remote Status: Select **LOC** or **RE**.

LOC The host computer is blocked from sending remote commands. Any write commands sent to the instrument will be rejected.

RE The host computer is allowed to send write commands. See the **ACT** (No Activity Timer) in the Secure Menu for additional information.

Addr (Option 995, 996, Serial Communications) Indicator Address: Set from **1** to **FF**. This number (hexadecimal, base 16) must match the address number used by the host computer. Viewed only in this menu. To change this parameter, see **Addr** in the Secure Menu.

SECURE MENU

Hold **▲** **↩** **UP ARROW & ENTER** for 5 Seconds. Press **↪** **INDEX** to advance to the next menu item. The display will alternate between the menu item and the programmed value. Press **▲** **UP ARROW** or **▼** to change the programmed value in the display. Press **↩** **ENTER** to retain the value.

OUTPUTS ARE DISABLED (TURNED OFF) WHILE INDICATOR IS IN SECURE MENU.

SECr Security Code: See the Security Level Selection and the Password Table in this manual, in order to enter the correct password.

inP Input Type: Select one of the following. Refer to the Input wiring section for the proper wiring.

- J- IC** Type "J" Thermocouple (NIST)
- KA** Type "K" Thermocouple
- E-** Type "E" Thermocouple
- t-** Type "T" Thermocouple
- L-** Type "L" Thermocouple (DIN)
- n-** Type "N" Thermocouple
- r- 13** Type "R" Thermocouple
- S- 10** Type "S" Thermocouple
- b-** Type "B" Thermocouple
- C-** Type "C" Thermocouple
- P392** 100 ohm Platinum (NIST 0.00392 $\Omega/\Omega/^\circ\text{C}$)
- n 120** 120 ohm Nickel
- P385** 100 ohm Platinum (DIN 0.00385 $\Omega/\Omega/^\circ\text{C}$)
- IP38** 1000 ohm Platinum (DIN 0.00385 $\Omega/\Omega/^\circ\text{C}$)
- Cur** DC Current Input 0.0 to 20.0 or 4.0 to 20.0 mA.
- Vol t** DC Voltage Input 0.0 to 5.0 or 1.0 to 5.0 volts.
- d iFF** DC Voltage Input -10 to +10 mV.
- - - -** Reserved

OSUP Zero Suppression: Select **On** or **OFF**. Only with Current and Voltage input types.

- OFF** The input range will start at 0 (zero) Input.
- On** The input range will start at 4.00 mA or 1.00 V.

Un it **F**, **C** or **nonE**.

- F** $^\circ\text{F}$ descriptor is On and temperature inputs will be displayed in actual degrees Fahrenheit.
- C** $^\circ\text{C}$ descriptor is On and temperature inputs will be displayed in actual degrees Celsius.
- nonE** $^\circ\text{F}$ and $^\circ\text{C}$ descriptors will be Off. This is only available with Current and Voltage Inputs.

dPt Decimal Point Positioning: Select **0**, **0.0**, **0.00**, **0.000**, or **0.0000**. On temperature type inputs this will only effect the Process Value, **RH**, **R2H**, **R1Lo**, **R2Lo**, and **InPt**. For Current and Voltage Inputs all Menu Items related to the Input will be affected.

0 No decimal Point is selected. This is available for all Input Types.

0.0 One decimal place is available for Type J, K, E, T, L, RTD's, Current and Voltage Inputs.

0.00 Two decimal places is only available for Current and Voltage Inputs.

0.000 Three decimal places is only available for Current and Voltage inputs.

0.0000 Four decimal places is only available for Current and Voltage inputs.

InPt Input Fault Timer: Select **OFF**, **0.1** to **540.0** minutes. Whenever an Input is out of range (**UFL** or **OFL** displayed), shorted, or open the timer will start. When the time has elapsed, the indicator will revert to a safe condition (Output Off, Flashing Display). If **OFF** is selected, the Input Fault Timer will not be recognized (time = infinite).

SEnC Sensor Rate of Change: Select **OFF**, **1** to **4000** °F, °C, or counts per 1 second period. This value is usually set to be slightly greater than the fastest process response expected during a 1 second period, but measured for at least 2 seconds. If the process is faster than this setting, the **SEnC bAd** error message will appear. The outputs will then be turned off. This function can be used to detect a runaway condition, or speed up detection of an open thermocouple. Press and hold the  keys for 5 seconds to reset.



Note: The total scaling capability of the instrument when programmed as a current or voltage input is 65500 counts. Remember that due to the total accuracy of the instrument, the displayed value has a tolerance of ± 66 counts ($\pm 0.1\%$). We recommend that you scale the instrument appropriately for your application. Extending the resolution of the instrument beyond the level of resolution of your input device (transmitter, etc.) is not recommended.

SCAL Scale Low: Select **100** to **65500** counts below **SCAH**. The total span between **SCAL** and **SCAH** must be within 65500 counts. Maximum setting range is -32750 to +32750 counts. For Current and Voltage inputs, this will set the low range end. Viewable only for Thermocouple and RTD ranges.

SCAH Scale High: Select **100** to **65500** counts above **SCAL**. The total span between **SCAL** and **SCAH** must be within 65500 counts. Maximum setting range is -32750 to +32750 counts. For Current and Voltage inputs, this will set the high range end. Viewable only for Thermocouple and RTD ranges.

ALARM TYPE AND ACTION (if present)



Caution: In any critical application where failure could cause expensive product loss or endanger personal safety, a redundant limit indicator is required.

When Alarm Power Interrupt, **AlP**, is programmed **On** and alarm Reset, **AlrE**, is programmed for **Hold**, the alarm will automatically reset upon a power failure and subsequent restoration if no alarm condition is present.

If Alarm Inhibit, **AlIH**, is selected **On**, an alarm condition is suspended upon power up until the process value passes through the alarm set point once. Alarm inhibit can be restored as if a power up took place by pressing the **RST** RESET key for 5 seconds.



Warning: Resetting a high alarm inhibit will not cause an alarm to occur if the Process Value does not first drop below the high alarm setting. Do not use the Alarm Inhibit feature if a hazard is created by this action. Be sure to test all combinations of high and low alarm inhibit actions before placing indicator into operation.

- AL 1** Alarm 1 function: Select **OFF**, **Lo**, **H**, **HLo**.
- OFF** Alarm 1 is disabled. No Alarm 1 menu items appear in the Secondary or Secure menus.
- Lo** Low Alarm Only. **AlLo** appears in the Secondary Menu.
- H** High Alarm Only. **AlH** appears in the Secondary Menu.
- HLo** High and Low Alarms. Both **AlLo** and **AlH** appear in the Secondary Menu, and share the same Alarm 1 Relay output.

If **AL 1** is set to **OFF**, go to **AL 2** below.

- AlrE** Alarm 1 Reset: Select **OnOFF** or **Hold**.
- OnOFF** Automatic Reset.
- Hold** Manual Reset. Reset (acknowledge) by pressing the **RST** RESET key for 5 seconds.
- AlP** Alarm 1 Power Interrupt: Select **On** or **OFF**.
- On** Alarm Power Interrupt is **On**.
- OFF** Alarm Power Interrupt is **OFF**.
- AlIH** Alarm 1 Inhibit: Select **On** or **OFF**.
- On** Alarm Inhibit is **On**. Alarm action is suspended until the process value first enters a non-alarm condition.
- OFF** Alarm Inhibit is **OFF**.
- AlSt** Alarm 1 Output State: Select **CLOS** or **OPEN**.
- CLOS** Closes Contacts at Alarm Set Point.
- OPEN** Opens Contacts at Alarm Set Point.

- ALP** Alarm 1 Lamp: Select **On** or **Off**.
On Alarm Lamp is ON when alarm contact is closed.
Off Alarm Lamp is OFF when alarm contact is closed.
- Ad** Alarm 1 Differential: Select **1** to **9999** degrees or counts.
- Atd** Alarm 1 Time Delay: Select **Off**, **1** to **8000** seconds.
Off Alarm function will operate as triggered.
1 - 8000 Alarm function will operate if it is present for longer than the time set.
- AL2** Alarm 2 function: Select **Off**, **Lo**, **H**, **HLo**.
Off Alarm 2 is disabled. No Alarm 2 menu items appear in the Secondary or Secure menus.
Lo Low Alarm Only. **ALLo** appears in the Secondary Menu.
H High Alarm Only. **ALH** appears in the Secondary Menu.
HLo High and Low Alarms. Both **ALLo** and **ALH** appear in the Secondary Menu, and share the same Alarm 2 Relay output.

If **AL2** is set to **Off**, the Secure Menu ends.

- AR-E** Alarm 2 Reset: Select **OnOff** or **Hold**.
OnOff Automatic Reset.
Hold Manual Reset. Reset (acknowledge) by pressing the **RST** RESET key for 5 seconds.
- ARP** Alarm 2 Power Interrupt: Select **On** or **Off**.
On Alarm Power Interrupt is **On**.
Off Alarm Power Interrupt is **Off**.
- AIH** Alarm 2 Inhibit: Select **On** or **Off**.
On Alarm Inhibit is **On**. Alarm action is suspended until the process value first enters a non-alarm condition.
Off Alarm Inhibit is **Off**.
- ARSt** Alarm 2 Output State: Select **CLOS** or **OPEN**.
CLOS Closes Contacts at Alarm Set Point.
OPEN Opens Contacts at Alarm Set Point.
- ALP** Alarm 2 Lamp: Select **On** or **Off**.
On Alarm Lamp is ON when alarm contact is closed.
Off Alarm Lamp is OFF when alarm contact is closed.
- Ad** Alarm 2 Differential: Select **1** to **9999** degrees or counts.
- Atd** Alarm 2 Time Delay: Select **Off**, **1** to **8000** seconds.
Off Alarm function will operate as triggered.
1 - 8000 Alarm function will operate if it is present for longer than the time set.
- Addr** (Option 995, 996, Serial Communications) Indicator Address: Set from **1** to **FF**. This number (hexadecimal, base 16) must match the address number used by the host computer.

- baud** (Option 995, 996, Serial Communications) Communication Baud Rate: Select **300**, **1200**, **2400**, **4800**, **9600**, or **19200**. This number must match the baud rate used by the host computer.
- naT** (Option 995, 996, Serial Communications) No Activity Timer: Set from **OFF** or **1** to **99** minutes.
- 1 - 99** Maximum time between host computer accesses. If timer counts to 0, **CHCC LoeE** will be displayed.
- OFF** No Activity Timer function is disabled.

SPECIFICATIONS

Selectable Inputs:

Thermocouple, RTD, DC Voltage, or DC Current selectable.

Input Impedance:

Thermocouple = 3 megohms minimum. RTD current = 200 μ A.

Current = 10 ohms.

Voltage = 5000 ohms.

Sensor Break Protection: De-energizes indicator output to protect system after customer set time. (See **InPt** in Secure Menu.)

Alarm Range: Selectable (See Range Chart Page 18).

Display: One 6 digit, 7 segment 0.56" high LEDs.

Accuracy: $\pm 0.1\%$ of span, ± 1 least significant digit.

Resolution: 1 degree or 0.1 degree, selectable, or one count.

Line Voltage Stability: $\pm 0.05\%$ over the supply voltage range.

Temperature Stability: 50 ppm / $^{\circ}$ C typical, 100 ppm / $^{\circ}$ C maximum.

Isolation:

Relay outputs: 1500 VAC to all other inputs and outputs.

24 VDC Loop Power: 500 VAC to all inputs and outputs.

Process Output: 500 VAC to all other inputs and outputs.

Supply Voltage: 100 to 240 VAC, nominal, +10 -15%, 50 to 400 Hz. single phase; 132 to 240 VDC, nominal, +10 -20%.

Power Consumption: 5VA maximum.

Operating Temperature: -10 to +55 $^{\circ}$ C (+14 to 131 $^{\circ}$ F).

Storage Temperature: -40 to +80 $^{\circ}$ C (-40 to 176 $^{\circ}$ F).

Humidity Conditions: 0 to 90% up to 40 $^{\circ}$ C non-condensing 10 to 50% at 55 $^{\circ}$ C non-condensing.

Memory Backup: Nonvolatile memory. No batteries required.

Alarm Relay: SPDT, 10 A @ 240 VAC resistive; 1/4 hp @ 120 VAC, 1/3 hp @ 240 VAC.

Loop Power Supply (isolated): 24VDC @ 50mA, regulated.

Panel Cutout: 45 mm x 92 mm (1.772" x 3.620").

Depth Behind Mounting Surface: 100.8 mm (3.97").

Weight: 454 g (16 oz).

Agency Approvals: CE, UL CUL.

Front Panel Rating: IP66, (Type 4X).

Input Ranges (Field Selectable) Thermocouple Types

Input Range	Type J* or L*	Type K*	Type T*	Type E*
1°F 1°C	-100 to +1600 -73 to +871	-200 to +2500 -129 to +1371	-350 to +750 -212 to +398	-100 to +1800 -73 to +982
Input Range	Type R	Type S	Type B	Type C
1°F 1°C	0 to 3200 -17 to +1760	0 to 3200 -17 to +1760	-100 to +2372 -73 to +1300	-100 to +2372 -73 to +1300
Input Range	Type N*	* These Input Types can be set for 0.1° display.		
1°F 1°C	-100 to +2372 -73 to +1300			

RTD Types

Input Type	100 Ohm Platinum 0.00385 DIN Curve*	100 Ohm Platinum 0.00392 Nist Curve*	120 Ohm Nickel 0.00628 US Ind. Curve*	1000 Ohm Platinum 0.00385 Nist Curve*
Range 1°F 1°C	-328 to +1607 -200 to +875	-328 to +1607 -200 to +875	-112 to +608 -80 to +320	-328 to +1607 -200 to +875

Process Input Types

The 0 to 20 mADC, 4 to 20 mADC, 0 to 10 VDC, 2 to 10 VDC, and -10 to +10 mVDC inputs are fully scalable from a minimum of 100 counts span placed anywhere within the within the range of -32750 to +32750. Decimal point position is adjustable from the zero place (9999), tenths (999.9), hundredths (99.99), thousandths (9.999), or ten thousandths (.9999).

DIAGNOSTIC ERROR MESSAGES

DISPLAY	MEANING	OUTPUTS	ACTION REQUIRED
No display lighted	Display is blank. Instrument is not getting power, or the supply voltage is too low.	Alarms inactive	Check that the power supply is on, or that the external fuses are good.
FAIL TEST	Fail test appears upon power up if the internal diagnostics detect a failure. This message may occur during operation if a failure is detected. Displays flash.	Alarms inactive	The display alternate between FAIL TEST and one of the following messages: FACT dFLT : Memory may be corrupted. Press the ENTER key and the DOWN ARROW key to start the factory default procedure. Recheck indicatorler programming. rEt FACT : Unrecoverable error, return to factory for service.
CHEC AL 1, CHEC AL 2	This message will appear upon power up if A IL 0 , A IH 1 , A 2Lo , or A 2H 1 is set outside of the SCAL or SCAH values.	Alarms active	Correct the A IL 0 , A IH 1 , A 2Lo , or A 2H 1 values by programming new values.
CHEC L or E	This message appears if the Serial Communications has timed out.	Alarms active	Restore the communications line and switch the L or E to L UC .
CHEC CAL	Check calibration appears as an alternating message if the instrument calibration nears tolerance edges.	Alarms active	Remove the instrument for service and / or recalibration. To reset use the INDEX & ENTER keys.
	Check calibration appears as a flashing message if the instrument calibration exceeds specification.	Alarms inactive	Remove the instrument for service and / or recalibration. To reset use the INDEX & ENTER keys.

DIAGNOSTIC ERROR MESSAGES

DISPLAY	MEANING	OUTPUTS	ACTION REQUIRED
UFL or OFL	Underflow or Overflow: Process value has exceeded input range ends.	Alarms active	Input signals may normally go above or below range ends. If not, check input and correct.
bAd inP	For RTD inputs RTD is open or shorted.	Alarms active	To reset use the INDEX & ENTER keys. When InPt (input fault timer) has been set for a time, the outputs will be turned off after the set time. Setting the time to OFF causes the outputs to remain active, however UFL or OFL will still be displayed. Correct or replace sensor. To reset use the INDEX & ENTER keys.
OPEn inP	For THERMOCOUPLE inputs thermocouple is open.	Alarms Active	

DIMENSIONS

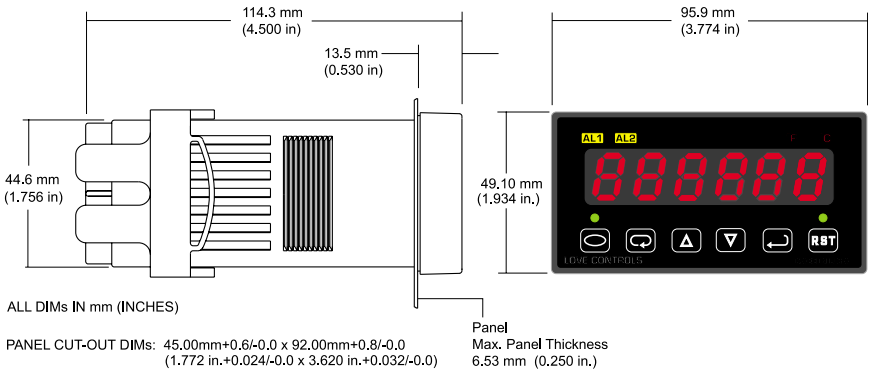

LOVE CONTROLS

a Division of Dwyer Instruments, Incorporated
 PO Box 338 ◯ Michigan City, IN 46361-0338
 (800) 828-4588 ◯ (219) 879-8000 ◯ FAX (219) 872-9057
www.love-controls.com