

DL

Integrated Temperature Controls

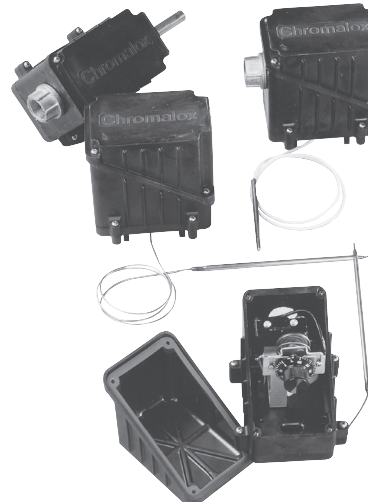

- Line or Ambient Sensing Thermostats
- Solid State and Electro-Mechanical Controls
- Rugged, Corrosion Resistant Construction
- NEMA 4X Design with Corrosion and Weather Resistant Ryton® Construction
- Ambient Sensing
 - 120 - 480 Vac
 - 0 - 225°F Temp. Rating
 - 9/16" OD x 4" SS Probe
 - Ordinary & Hazardous Area (Div. 2) Approvals
- Bulb & Capillary
 - 120 - 480 Vac
 - 0 - 400°F Setpoint Range
 - 1/4" OD x 7-1/4" SS Bulb and Capillary
 - Ordinary & Hazardous Area (Div. 2) Approvals
- Solid State
 - 20 A @ 120 - 240 Vac
 - Setpoint Ratings:
 - 0 - 100°F
 - 50 - 250°F
 - 200 - 600°F
 - Ordinary Area Approvals

Description

The DL Series Single Point On/Off Temperature Controls from Chromalox represent the state of the art in heat tracing and are available in five models to handle a broad range of applications. Models include two ambient sensing thermostats, two line sensing thermostats and a line sensing solid state controller. These high-quality models combine temperature control and power connection in a convenient, easy to use and economical package.

Applications

- Hydrocarbon and Chemical Product Piping
- Process Temperature Maintenance
- Fluid Flow and Viscosity Maintenance
- Freeze Protection

Features

- Integrated Controls and Power Connections reduce installation hardware
- Molded of Durable Plastic Material (Ryton® PPS)¹
- High Service Temperature
- Corrosion Resistant
- Thermal Stability
- Non-Flammability
- High Strength and Rigidity

- Stainless Steel Sensor Sheath
- Hermetically Sealed Switches on EP models permit control in Div. 2 hazardous areas
- Stainless Steel Hardware to ensure the integrity of the system
- Cable Terminations inside enclosure reduce installation time and cost
- Liquid Tight Design prevents moisture from reaching the electrical connections. All models are rated NEMA 4X.

Approvals²

UL, CSA, FM is carried by most models, consult specific product information.

UL Listed for ordinary areas

CSA Certified for ordinary and:

- Class I, Div. 2, Groups A, B, C, D
- Class II, Div. 2, Groups F, G

FM Approved for ordinary and:

- Class I, Div. 2, Groups B, C, D
- Class II, Div. 2, Groups F, G
- Class III, Div. 2 Areas.

Notes —

1. Ryton® is a registered trade name of Phillips Chemical Company.
2. Depends on specific model and cable applied.

DL

Integrated Temperature Controls *(cont'd.)*

RTAS & RTAS-EP Ambient Sensing

RTAS is an ambient-sensing thermostat which is generally used for freeze protection in ordinary (non-hazardous) areas. The thermostat is mounted through the end of the oblique sided enclosure lid. In fact, because there is so much room in this model, multiple heating cables can be terminated. The stainless steel sheathed, inverted bellows probe provides good sensitivity, resulting in more accurate control.

RTAS-EP is a modified version of the RTAS which utilizes a hermetically sealed switch. Since this switch has no arcing contacts, it can be used in Division 2 Hazardous Areas.

Specifications

Temp. Setpoint Range — 0 to 225°F (-18 to 107°C) for RTAS/RTAS-EP

Microswitch® Rating — 22 Amps SPDT for RTAS; 11 Amps, RTAS-EP

Scale Division — 10°F (5.6°C)

Max. Sensor Exposure Temp. — 250°F (121°C)

Sensor Dimensions — 9/16" Dia. x 3" Long

Operating Ambient Temp. Range — -40°F to 160°F (-40 to 71°C)

Factory Preset and Calibrated — 40°F

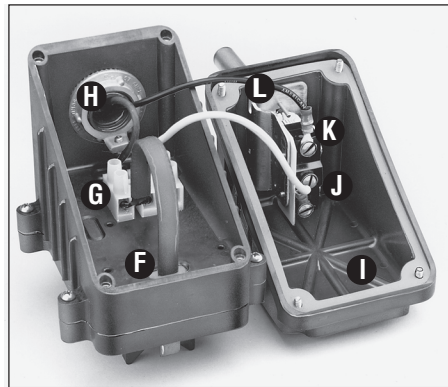
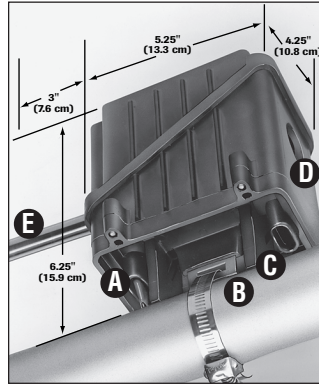

Construction

- A** Strategically placed cable entries allow maximum flexibility for insulation (Heating cable cut away for clarity).
- B** Stainless steel tiedown support provides positive attachment to pipes.¹
- C** Heavy duty support legs give stable pipe mounting and provide conduit clearance for applications with up to three inches of insulation.
- D** Opening for 3/4" (20 mm) conduit hub.¹
- E** Stainless steel sheath temperature sensor.
- F** Cable grommets provide water-tight seal between base, box and cable. Use GRSR with all self-regulating cables. Use GRCW with constant wattage cables. One of each grommet included in kit. See table below for spare grommets.
- G** Three position terminal block for easy wiring.
- H** Power wiring entry. Conduit hub not included.
- I** Gasket provides water-tight seal between box and lid. It is affixed to the lid and holds the mounting hardware during assembly.
- J** Thermostat switch.
- K** Setpoint adjustment knob.
- L** Setpoint indicator.

Note 1 — Refer to DL & EL General Application Accessories at the end of this section.

Spare Grommets

PCN

GRS	RTD/Capillary type	385000
GRO	Blank	385019
GRSR	Self-regulating cable type	389714
GRCW	Constant wattage cable type	389722

Ordering Information

Model	PCN	Switch Rating (Amps/Volts)	Max. Continuous Exposure Temp.		Max. Intermittent Exposure Temp.		Wt. (Lbs.)
			°F	°C	°F	°C	
RTAS	389589	22A @ 120 - 480	400	200	500	260	2
RTAS-EP	389597	11A @ 120 - 250	400	200	500	260	2

Stock Status: S = stock AS = assembly stock NS = non-stock
To Order—Specify model, PCN and quantity.

Heating Cable

DL

Integrated Temperature Controls (cont'd.)

RTBC & RTBC-EP Bulb & Capillary

RTBC is a line-sensing thermostat which is generally used for process temperature maintenance applications in ordinary (non-hazardous) areas. The thermostat is mounted within the enclosure and the capillary is brought out through one of the openings in the bottom of the box. This design provides extra protection for the capillary, especially when the control is mounted on a pipe, for heat tracing applications. The three foot long stainless steel capillary provides good flexibility in mounting locations.

RTBC-EP is a modified version of the RTBC which utilizes a hermetically sealed switch. Since this switch has no arcing contacts it can be used in Division 2 Hazardous Areas.

Specifications

Temp. Setpoint Range — 0 to 400°F (-18 to 200°C) for RTBC, RTBC-EP

Microswitch® Rating — 22 Amps SPDT for RTBC; 11 Amps, RTBC-EP

Minor Scale Division — 10°F (5.6°C)

Max. Sensor Exposure Temp. — 450°F (230°C)

Sensor Dimensions — 1/4" (6.4mm) OD x 7-1/4" (18.4cm) L Bulb, 3' (1m) Capillary

Operating Ambient Temp. Range — -40°F to 160°F (-40 to 71°C)

Factory Preset and Calibrated — 200°F (93°C) for RTBC, RTBC-EP

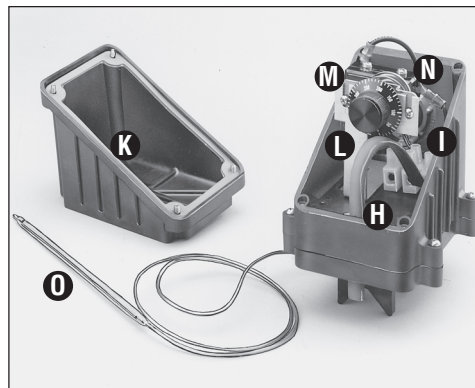
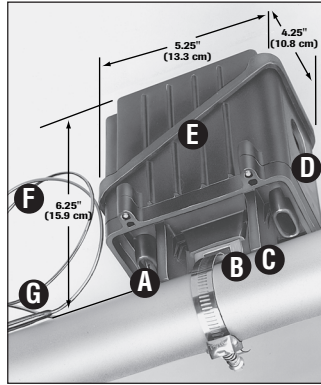

Construction

- A** Strategically placed cable entries allow maximum flexibility for insulation (Heating cable cut away for clarity).
- B** Stainless steel tiedown support provides positive attachment to pipes.¹
- C** Heavy duty support legs give stable pipe mounting and provide conduit clearance for applications with up to three inches of insulation.
- D** Opening for 3/4" (20 mm) conduit hub.¹
- E** Oblique sided box and cover allow easy access for wiring.
- F** Stainless steel capillary (3 ft/1m long).
- G** Stainless steel sensing bulb.
- H** Cable grommets provide water-tight seal between base, box, cable and capillary. Use GRSR with all self-regulating cables. Use GRCW with constant wattage cables. One of each grommet included in kit. See table below for spare grommets.
- I** Three position terminal block for easy wiring.
- J** Power wiring entry. Conduit hub not included.¹
- K** Gasket provides water-tight seal between box and lid. It is affixed to the lid and captures the mounting hardware.
- L** Thermostat mounting bracket.
- M** Setpoint adjustment knob.
- N** Thermostat switch.
- O** Stainless steel sensing bulb.

Note 1 — Refer to DL & EL General Application Accessories at the end of this section.

Spare Grommets

PCN

GRS	RTD/Capillary type	385000
GRO	Blank	385019
GRSR	Self-regulating cable type	389714
GRCW	Constant wattage cable type	389722

Ordering Information — RTBC

Model	PCN	Switch Rating (Amps/Volts)	Max. Continuous Exposure Temp.		Max. Intermittent Exposure Temp.		Wt. (Lbs.)
			°F	°C	°F	°C	
RTBC	389600	22A @ 120 - 480	400	200	500	260	2
RTBC-EP	389618	11A @ 120 - 250	400	200	500	260	2

Stock Status: S = stock AS = assembly stock NS = non-stock
To Order—Specify model, PCN and quantity.

DL

Integrated Temperature Controls *(cont'd.)*

RTSS

Solid State Line Sensing (RTD) Control

RTSS is a line-sensing solid state controller which is used for process temperature maintenance applications where more precise temperature control is required. This control is supplied with a specially designed RTD sensor. The sensor has a stainless steel sheath and waterproof insulated TFE lead wires. The controller provides excellent accuracy and high current switching ability in a small enclosure.

Thermostat Specifications

Temperature Setpoint Range

RTSS-A = 0 - 100°F (-18 - 38°C)

RTSS-B = 50 - 250°F (10 - 121°C)

RTSS-C = 200 - 600°F (93 - 316°C)

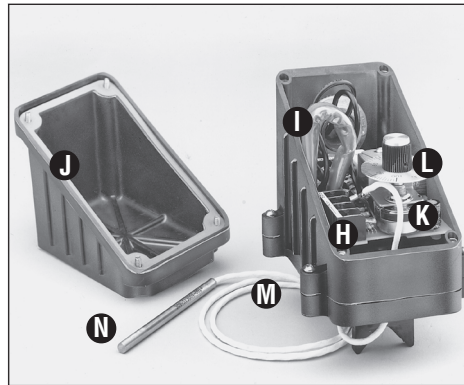
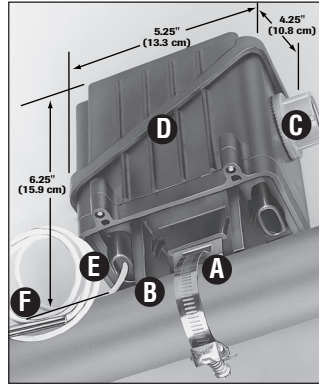

Construction

- A** Stainless steel tiedown support provides positive attachment to pipes.¹
- B** Heavy duty support legs give stable pipe mounting and provide conduit clearance for applications with up to three inches of insulation.
- C** Opening for 3/4" (20 mm) conduit hub. Conduit hub not included.
- D** Oblique sided box and cover allow easy access for wiring.
- E** Entry brings the RTD leads into the box through a special grommet.
- F** RTD and leadwire.
- G** Cable grommets provide water-tight seal between base and box (not visible). Use GRSR with all self-regulating cables. Use GRCW with constant wattage cables. One of each grommet included in kit. See table below for spare grommets.
- H** Built-in terminal blocks for easy wiring.
- I** Power wiring entry. Conduit hub not included.¹
- J** Gasket provides water-tight seal between box and lid. It is affixed to the lid and captures the mounting hardware.
- K** Solid state controller.
- L** Setpoint adjustment knob.
- M** RTD leads with sealed TFE sheath.
- N** Stainless steel sensing bulb.

Note 1 — Refer to DL & EL General Application Accessories at the end of this section.

Spare Grommets

PCN

GRS	RTD/Capillary type	385000
GRO	Blank	385019
GRSR	Self-regulating cable type	389714
GRCW	Constant wattage cable type	389722

Ordering Information — RTSS

Model	PCN	Switch Rating (Amps/Volts)	Max. Continuous Exposure Temp.		Max. Intermittent Exposure Temp.		Wt. (Lbs.)
			°F	°C	°F	°C	
RTSS-A	385908	20A @ 120 - 240	400	200	500	260	2
RTSS-B	385916	20A @ 120 - 240	400	200	500	260	2
RTSS-C	385924	20A @ 120 - 240	400	200	500	260	2

Stock Status: S = stock AS = assembly stock NS = non-stock
To Order—Specify model, PCN and quantity.