

BriskHeat® Heating Cords are designed for use on small diameter tubes, vessels or any place where space is limited. Heating cords can be wrapped around tubing as small as 1/8" (3.2mm) diameter. The double braided fiberglass outer sheath ensures durability for laboratory, production, or maintenance applications.

Specifications:

- Maximum Exposure Temperature: 900°F (482°C)
- Wrap around Diameters as Small as 1/8" (3.2mm)
- Fiberglass Knit and Braided Construction
- Nominal Watts per Square Inch (mm): 1.8 (0.003)
- Fiberglass Outer Sheath
- Suitable for Electrical Conductive Surfaces
- 120 or 240VAC
- Includes High Temperature Tie Downs

Temperatures up to



900°F (482°C)

Additional Item Needed



Temperature Controller

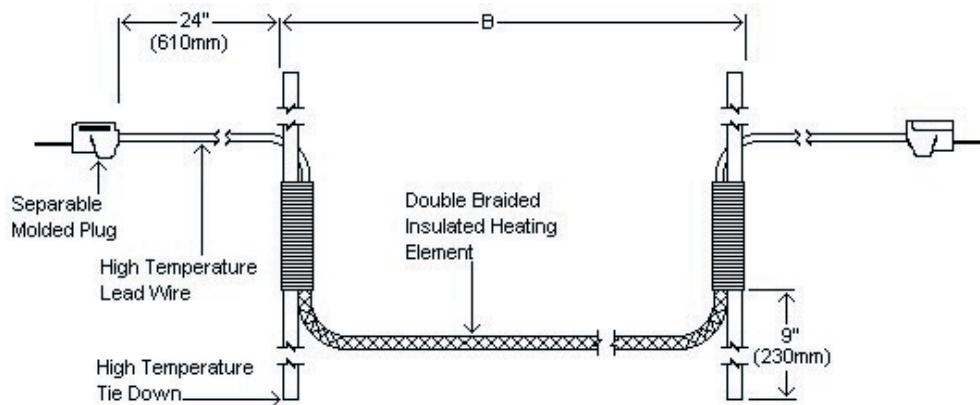

Diameter in (mm)	Size B in (mm)	Total Watts	Part No. 120VAC	Part No. 240VAC
3/16 (4.8)	36 (915)	64	HTC451001	N/A
3/16 (4.8)	72 (1829)	125	HTC451002	N/A
3/16 (4.8)	144 (3658)	260	HTC451003	N/A